

WILLIAM BECHTEL

FROM MOLECULES TO NETWORKS:
ADOPTION OF SYSTEMS APPROACHES IN
CIRCADIAN RHYTHM RESEARCH

ABSTRACT

In the 1990s circadian rhythm researchers made enormous progress in identifying the components and operations within the responsible mechanism in various species using the tools of molecular biology. In the past decade it has proven essential to supplement these with the tools of systems biology both to identify additional components but especially to understand how the mechanism can generate circadian phenomena. This has proven especially important since research has shown that individual neurons in the mammalian mechanism are highly variable ~~in their behavior~~ and that the way they are organized in networks is crucial to generating circadian behavior.

1. INTRODUCTION

From its roots in the study of circadian rhythms observed in physiology and behavior, circadian rhythm research rapidly adopted and energetically pursued a molecular biological approach in the last decades of the 20th century. This research has been highly productive in revealing many of the components of the circadian mechanisms in each of the major model systems: cyanobacteria, fungi, plants, and various animals (especially fruit flies and mice). But success in decomposing the mechanisms has also generated challenges in recomposing them, a crucial step in understanding how they work. Although in some fields it is possible for researchers to literally recompose mechanisms (e.g., by reconstituting a chemical reaction in vitro), in other ~~cases~~ researchers must do so more indirectly, either by imagining the interactions of the components performing their various operations or by constructing computational models that demonstrate how the hypothesized set of components would interact if they operated in the manner characterized. Imagination suffices when mechanisms are relatively simple, involving components performing linear operations and organized sequentially. But when the parts identified operate non-linearly and are organized non-sequentially, such an approach

fails. The alternative, increasingly being pursued in circadian rhythm research, is to turn to computational modeling and dynamical systems analysis.¹

A further challenge stems from the fact that underlying the strategy of decomposing mechanisms is the assumption that the mechanism itself and each of its components operate largely in isolation from other mechanisms or components so that the whole system exhibits what Herbert Simon referred to as *near decomposability*.² Assuming near decomposability is a heuristic, and a characteristic of heuristics is that they can fail. Increasingly biologists are learning that the mechanisms they study are less decomposable than they thought, and circadian mechanisms are no exceptions. The challenge is to relax the decomposability assumption and incorporate the influences from other components that alter the behavior of the components into one's account without losing the ability to explain the operation of the mechanism in terms of its components. Once again, this is leading circadian researchers to turn to computational modeling, which has the resources to characterize multiple interactions affecting individual components while they operate within a mechanism.

My focus in this paper will be on the steps in recomposing circadian mechanisms in the last decade that has led to a focus on networks at various levels of organization, including ones at which clock mechanisms interact with other biological mechanisms. This has resulted in an increased focus on networks as opposed to individual components and on the employment of tools from systems biology to understanding the responsible mechanisms. Before examining these developments, though, I will set the stage by introducing circadian rhythms research and briefly describing the results of the more traditional mechanist project of decomposing circadian mechanisms.

-
- 1 Mechanisms and mechanistic explanation has been the focus of considerable discussion in recent philosophy of science. See, for example, William Bechtel and Robert C. Richardson, *Discovering Complexity: Decomposition and Localization as Strategies in Scientific Research*. Cambridge (Mass.): MIT Press. 1993 edition published by Princeton University Press 1993/2010; Peter Machamer, Lindley Darden, and Carl F. Craver, "Thinking About Mechanisms", in: *Philosophy of Science* 67, 2000, pp. 1-25. In recent papers I have distinguished basic mechanistic explanation, which focuses on recomposing mechanisms through mental simulation, and dynamic mechanistic explanation, which appeals to computational model and dynamical systems theory to recompose mechanisms and explain how they function. See William Bechtel, "Mechanism and Biological Explanation", in: *Philosophy of Science* 78, 4, 2011, pp. 533-57; William Bechtel and Adele Abrahamsen, "Dynamic Mechanistic Explanation: Computational Modeling of Circadian Rhythms as an Exemplar for Cognitive Science", in: *Studies in History and Philosophy of Science Part A* 41, 3, 2010, pp. 321-33.
 - 2 Herbert A. Simon, "The Architecture of Complexity: Hierarchic Systems", in: *Proceedings of the American Philosophical Society* 106, 1962, pp. 467-82.

2. FROM CIRCADIAN RHYTHMS TO CLOCK MECHANISMS

Circadian rhythms involve endogenously generated oscillations of approximately 24 hours (hence the term *circadian* from *circa* [about] + *dies* [day]) that affect a wide variety of physiological processes and behaviors. For example, human body temperature is lower during the night and raises during the day, varying by nearly a degree Celsius. These rhythms are entrainable to the local day-night cycle; when entrainment cues such as daylight are lacking, they free-run and thereby reveal that their period is not exactly 24 hours. This was one of the crucial features of circadian rhythms that convinced the pioneer circadian researchers in the middle of the 20th century that these rhythms were endogenously maintained and not responses to external cues. The evidence presented at the 1960 Symposium on Biological Clocks at Cold Springs Harbor largely settled the question of endogenous origin of circadian rhythms.³ While the mechanistic metaphor of a clock was widely embraced by many researchers and employed in the title of the 1960 symposium, the tools for actually investigating the clock mechanism were indirect, relying on such approaches as varying the period of the light-dark cycle or restricting light exposure to pulses at different parts of the cycle to see how they affected the mechanism.

In the two decades after 1960 a variety of researchers identified the locus and began decomposing the hypothesized clock. Although in single-cell organisms and in plants researchers assumed the mechanism was found in each cell, animal researchers assumed that the clock was localized within the brain. Richter discovered that lesions to the hypothalamus disrupted circadian behavior and concluded that circadian rhythms were generated “somewhere in the hypothalamus.”⁴ In 1972 two research groups further narrowed the locus to the suprachiasmatic nucleus (SCN), a bilateral nucleus located just above the optic chiasm that in the mouse consists of approximately 20,000 neurons. It was the target of projections from the retina, allowing for entrainment by light,⁵ and lesions to it rendered animals arrhythmic.⁶ Inouye and Kawamura showed, using multi-electrode record-

3 This conference in many respects marks the founding of circadian rhythm research as a distinct research field. The papers and some of the discussion were published in *Cold Spring Harbor Symposia on Quantitative Biology* 25, 1960.

4 Curt P. Richter, *Biological Clocks in Medicine and Psychiatry*. Springfield, IL: Charles C. Thomas 1965.

5 Robert Y. Moore and Nicholas J. Lenn, “A Retinohypothalamic Projection in the Rat”, in: *The Journal of Comparative Neurology* 146, 1, 1972, pp. 1-14.

6 Friedrich K. Stephan and Irving Zucker, “Circadian Rhythms in Drinking Behavior and Locomotor Activity of Rats Are Eliminated by Hypothalamic Lesions”, in: *Proceedings of the National Academy of Sciences (USA)* 69, 1972, pp. 1583-86; Robert Y. Moore and Victor B. Eichler, “Loss of a Circadian Adrenal Corticosterone Rhythm Following Suprachiasmatic Lesions in the Rat”, in: *Brain Research* 42, 1972, pp. 201-06.

ing, that isolated SCN tissue ~~alone~~ remained rhythmic.⁷ The case for this locus was made more compelling when in 1990 Ralph, Foster, Davis, and Menaker ~~demo~~strated that transplanting the SCN from a mutant hamster with a shortened rhythm into ventricles of a SCN-lesioned host restored rhythms in the recipient that corresponded to those of the donor.⁸

To explain how a localized mechanism could function as a clock, researchers needed to decompose it to identify its component parts and the operations they performed. This research proceeded independently using fruit flies during the same period as mammalian researchers were localizing the mammalian clock in the SCN. Since investigators beginning with Darwin viewed circadian rhythms as inherited, a natural strategy was to try to identify responsible genes. Seymour Benzer developed a strategy for identifying genes responsible for traits by exposing fruit flies to mutagenic agents and linking resulting aberrant traits to the mutated gene. In 1971, as a graduate student with Benzer, Konopka pursued this approach to circadian rhythms in fruit flies, creating mutants that were either arrhythmic or exhibited shortened (20 hour) or lengthened (28 hour) rhythms.⁹ He traced all these effects to a mutation at a common location on the X chromosome and named the responsible gene *period* (*per*). A few other loci at which mutations altered clock behavior were soon after identified in fruit flies and in fungi¹⁰ and a decade later in hamsters.¹¹ Initially much of the research focused on carefully describing the behavior of the mutants, including their responses to light pulses. Although there were several attempts to infer the mechanism from the behaviors of the mutants and other clues,¹² these efforts were unsuccessful in providing empirically grounded hypotheses until cloning technology made it possible to study the transcripts of genes and identify their protein products. Using this approach, in 1990 Hardin, Hall, and Rosbash demonstrated daily oscillations in both *per* RNA and the protein PER, and proposed a transcriptional-translational feedback loop mechanism whereby once PER was synthesized and transported back into the nucleus it would suppress its own transcription until it was degraded, after which more PER

-
- 7 Shin-Ichi T. Inouye and Hiroshi Kawamura, "Persistence of Circadian Rhythmicity in a Mammalian Hypothalamic „Island“ Containing the Suprachiasmatic Nucleus", in: *Proceedings of the National Academy of Sciences (USA)* 76, 1979, pp. 5962-66.
 - 8 Martin R. Ralph, Russell G. Foster, Fred C. Davis, and Michael Menaker, "Transplanted Suprachiasmatic Nucleus Determines Circadian Period", in: *Science* 247, 4945, 1990, pp. 975-78.
 - 9 Ronald J. Konopka and Seymour Benzer, "Clock Mutants of *Drosophila Melanogaster*", in: *Proceedings of the National Academy of Sciences (USA)* 89, 1971, pp. 2112-16.
 - 10 Jerry A. Feldman and Marian N. Hoyle, "Isolation of Circadian Clock Mutants of *Neurospora Crassa*", in: *Genetics* 75, 1973, pp. 605-13.
 - 11 Martin R. Ralph and Michael Menaker, "A Mutation of the Circadian System in Golden Hamsters", in: *Science* 241, 1988, pp. 1225-27.
 - 12 Leland N. Edmunds, *Cellular and Molecular Bases of Biological Clocks: Models and Mechanisms for Circadian Timekeeping*. New York: Springer-Verlag 1988.

could be synthesized (Figure 1).¹³ With appropriate delays for the various stages, they hypothesized that this process could generate 24-hour oscillations.

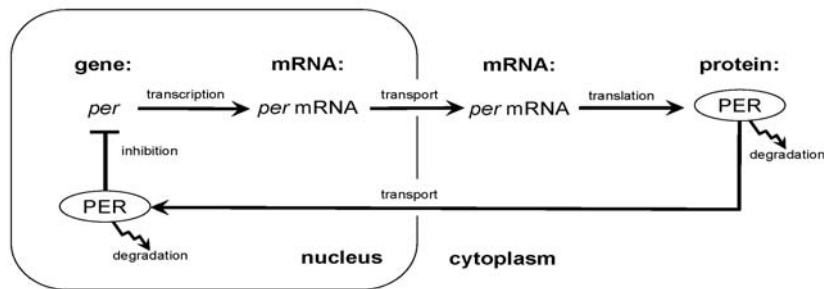

Figure 1. The translation-transcription feedback mechanism proposed by Hardin et al.

In the early 20th century engineers discovered, often to their chagrin, that negative feedback can generate oscillations and mathematically inclined biologists, noting the frequency of oscillatory behavior in living systems, explored the potential of negative feedback to create sustained oscillations. Goodwin, for example, developed a model based on the negative feedback mechanism that Jacob and Monod¹⁴ had proposed for gene regulation in bacteria.¹⁵ In simulations run on an analog computer, he found that he could only generate sustained oscillations when he included at least one non-linear function (involving the Hill coefficient, widely employed in kinetic analyses of biochemical reactions to characterize the number of molecules that must cooperate to achieve inhibition) and even then only when parameters were in restricted ranges.¹⁶ To determine whether the transcription-

13 Paul E. Hardin, Jeffrey C. Hall, and Michael Rosbash, "Feedback of the *Drosophila* *Period* Gene Product on Circadian Cycling of Its Messenger Rna Levels", in: *Nature* 343, 6258, 1990, pp. 536-40.

14 François Jacob and Jacques Monod, "Genetic Regulatory Systems in the Synthesis of Proteins", in: *Journal of Molecular Biology* 3, 1961, pp. 318-56.

15 Brian C. Goodwin, *Temporal Organization in Cells; a Dynamic Theory of Cellular Control Processes*. London: Academic 1963.

16 In his analog simulations Goodwin reported oscillatory behavior with values as low as 2 or 3 for the Hill coefficient, but shortly afterward Griffith found in digital simulations that undamped oscillations would only occur with values greater than 9, generally recognized as biologically unrealistic: see J. S. Griffith, "Mathematics of Cellular Control Processes I. Negative Feedback to One Gene", in: *Journal of Theoretical Biology* 20, 2, 1968, pp. 202-08. Accordingly, he concluded that negative feedback with a single gene product operating on a gene could never "give rise in practice to undamped oscillations in the concentrations of cellular constituents." Subsequently models, such as those of Goldbeter (discussed below) employ additional nonlinearities elsewhere in the model (e.g., involving the degradation of various components) and so are able to use

translation feedback loop proposed by Hardin et al. would be able to generate the phenomenon, Goldbeter elaborated on Goodwin's model. With parameters that he claimed were biologically plausible, Goldbeter's model generated sustained oscillatory behavior.¹⁷

The research described so far illustrated the combination of tools for decomposition and recombination in generating an account of a mechanism for circadian rhythms. The mutant research together with cloning techniques allowed researchers to decompose the mechanism, identify an important part—the gene *per*—and characterize an operation in which it engaged—being transcribed into RNA and a protein, both of which oscillated on a 24-hour cycle. This enabled them to recombine the mechanism by proposing a feedback process that could be represented in a diagram. Hardin et al. could verbally describe the behavior such a mechanism might exhibit, but Goldbeter's computational model showed that if the parts operated as Hardin et al., proposed, the mechanism would generate sustained oscillations.

At the same time as Goldbeter was developing his model, other researchers were identifying a host of additional genes in which mutations resulted in altered circadian rhythms and were able to specify the operations in which these figured. For example, by pursuing a strategy similar to Konopka's, Sehgal, Price, Man, and Young identified a second fruit fly gene, which they called *timeless* (*tim*), in which mutations resulted in altered rhythms.¹⁸ In further research they revealed that TIM forms a dimer with PER before entering the nucleus and it is the dimer that figures in inhibiting transcription of both *per* and *tim*.¹⁹ Adopting the same strategy with mice, Vitaterna, King, Chang, Kornhauser, Lowrey, McDonald, Dove, Pinto, Turek, and Takahashi identified a gene they named *Clock* in which mutations resulted in loss of circadian rhythms.²⁰ Homologues of *Clock* were found in fruit flies, and CLOCK was shown to bind to the promoter of *per* and *tim*. Two homologs of PER, PER1 and PER2, were soon after identified in mice, where they were shown to form dimers not with TIM but with two cryptochromes, CRY1 and CRY2. In sort order investigators determined that in mice CLOCK forms a dimer with BMAL1.

values of the Hill coefficient that are more biologically realistic.

- 17 Albert Goldbeter, "A Model for Circadian Oscillations in the *Drosophila* Period Protein (Per)", in: *Proceedings of the Royal Society of London. B: Biological Sciences* 261, 1362, 1995, pp. 319-24.
- 18 Amita Sehgal, Jeffrey L. Price, Bernice Man, and Michael W. Young, "Loss of Circadian Behavioral Rhythms and *Per* Rna Oscillations in the *Drosophila* Mutant *Timeless*", in: *Science* 263, 1994, pp. 1603-06.
- 19 Leslie B. Vosshall, Jeffrey L. Price, Amita Sehgal, Lino Saez, and Michael W. Young, "Block in Nuclear Localization of *Period* Protein by a Second *Clock* Mutation, *Timeless*", in: *Science* 263, 5153, 1994, pp. 1606-09.
- 20 Martha Hotz Vitaterna, David P. King, Anne-Marie Chang, Jon M. Kornhauser, Phillip L. Lowrey, J. David McDonald, William F. Dove, Lawrence H. Pinto, Fred W. Turek, and Joseph S. Takahashi, "Mutagenesis and Mapping of a Mouse Gene, *Clock*, Essential for Circadian Behavior", in: *Science* 264, 5159, 1994, pp. 719-25.

Another protein, REV-ERB α , was discovered to bind to the promoter of BMAL1 and inhibit its transcription and translation and various kinases were identified as figuring in the phosphorylation of PER and CRY, a factor crucial both in their transport into the nucleus and in their degradation.

The discovery of these additional parts and operations led to new challenges in recomposing the clock. Since each component could be related in one way or another to PER, it was possible to connect them into a common diagram in which the transcription-translation feedback loop involving PER was the central feature. Researchers recognized that there is a second feedback loop in which the action of BMAL1 in activating the production of REV-ERB α is subsequently inhibited when REV-ERB α inhibits the production of BMAL1. Numerous diagrams similar to Figure 2 appeared to illustrate how the various components were thought to be related so as to generate oscillations. However, although one might mentally rehearse the operations portrayed in Figure 1 to show that it might oscillate, this proved harder to do as additional components and feedback loops were introduced. This made it even more important to represent the hypothesized mechanism in computational models to determine how it will behave. In collaboration with Leloup, Goldbeter added terms and equations to his 1995 model to represent both the fruit fly²¹ and the mammalian²² circadian mechanism. In addition to capturing the basic oscillation, Leloup and Goldbeter demonstrated that the components hypothesized to entrain the clock to light-dark cycles could indeed modify the phase of the oscillator in an appropriate manner and that manipulations in the model that correspond to altering components of the clock could generate the patterns of known circadian pathologies such as delayed and advanced sleep phase syndromes.

21 Jean-Christophe Leloup and Albert Goldbeter, "A Model for Circadian Rhythms in *Drosophila* Incorporating the Formation of a Complex between the Per and Tim Proteins", in: *Journal of Biological Rhythms* 13, 1, 1998, pp. 70-87.

22 Jean-Christophe Leloup and Albert Goldbeter, "Modeling the Mammalian Circadian Clock: Sensitivity Analysis and Multiplicity of Oscillatory Mechanisms", in: *Journal of Theoretical Biology* 230, 4, 2004, pp. 541-62.

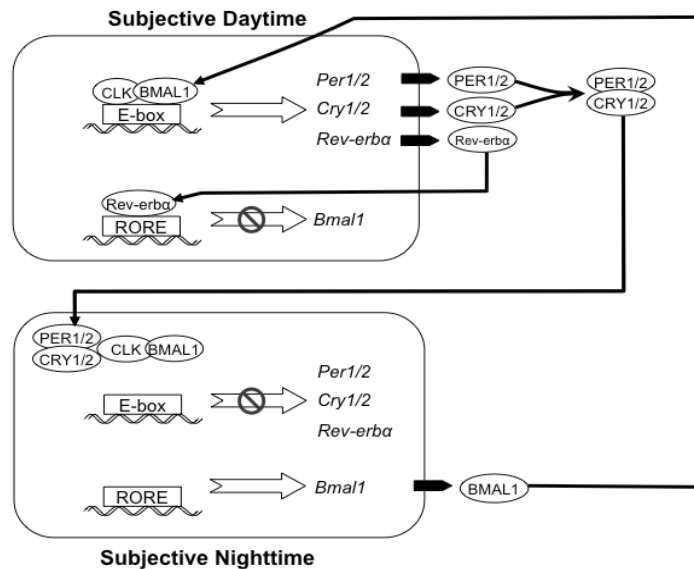

Figure 2. A representation of the mammalian circadian mechanism incorporating many of the additional components that were identified in the 1990s.

3. SYSTEMS BIOLOGICAL APPROACHES TO THE OSCILLATOR MECHANISM

The basic research on the circadian oscillator described in the previous section all fit within the framework of molecular biology although the modeling endeavors already foreshadowed the application of the approach of systems biology. Over the last decade the term *systems biology* has been adopted in many domains of biology to signify an approach that focuses on the integration and interaction of large numbers of components giving rise to behaviors that are not readily traced to individual components.²³ Two aspects of systems biology have been particularly important for circadian rhythm research. The first is the introduction of new techniques for identifying large numbers of components that figure in a mechanism (in contrast to the identification of individual parts one at a time as in the genetic research discussed above). For example, a genome wide screen using complementary DNA (cDNA) overexpression assays identified ROR α as an activator of BMAL1 transcription that competes with inhibitor REV-ERB α and yields a positive feedback loop.²⁴ Similar screening techniques revealed numerous addi-

23 Denis Noble, *The Music of Life: Biology Beyond the Genome*. Oxford: Oxford University Press 2006; Hiroaki Kitano (Ed.), *Foundations of Systems Biology*. Cambridge, (Mass.): MIT Press 2001; Sangdun Choi (Ed.), *Introduction to Systems Biology*. Totowa, NJ: Humana Press 2007.

24 Trey K. Sato, Satchidananda Panda, Loren J. Miraglia, Teresa M. Reyes, Radu D. Ru-

tional clock components, including various kinases that figure in post-translational modification of proteins. A small interfering RNA screen (siRNA) identified more than 200 genes, many of which figure in different cell-signaling pathways that affect amplitude and period of circadian oscillations.²⁵ One consequence of this use of systems approaches has been to reveal ways in which the clock mechanism is linked to and affected by other cell functions.

The second contribution is to bring the tools of dynamical systems analyses of mathematical models to bear in understanding mechanisms in which multiple interacting non-linear processes defeat the prospect of understanding the mechanism by tracing out its operations sequentially. Already in his 1995 model Goldbeter pioneered this approach: to show that the model produced sustained oscillations he showed that it generated limit cycle behavior. As I noted, Goldbeter continued this endeavor as new clock components were identified, developing models incorporating all the known constituents of the clock mechanism. While his models generated many features of circadian clock behavior, their very complexity made it difficult to determine operations in the mechanism were primarily responsible for specific behaviors. Many modelers accordingly prefer to construct reduced models that focus on select components and to manipulate (experiment on) these models to understand what individual components contribute. Accordingly, Smolen, Baxter, and Byrne developed a much reduced model for the fruit fly clock that, for example, did not distinguish PER and TIM and did not incorporate the transport of proteins back into the nucleus (instead incorporating a delay between different operations).²⁶ After establishing that their model generated appropriate oscillations, they explored whether all components of it were required to do so. By fixing the value for CLOCK concentrations they eliminated the second feedback loop involving REV-ERB α and showed that the feedback of PER and TIM on their own transcription was sufficient (as Goldbeter's first model had suggested). Interestingly, recently Relógio, Westermark, Wallach, Schellenberg, Kramer, and Herzl have reached the opposite conclusion.²⁷ Their model is somewhat more complex, and incorporates the competition between REV-ERB α and ROR α , but is still much simpler than Goldbeter's. When they fixed the variable correspond-

dic, Peter McNamara, Kinnery A. Naik, Garret A. FitzGerald, Steve A. Kay, and John B. Hogenesch, "A Functional Genomics Strategy Reveals Rora as a Component of the Mammalian Circadian Clock", in: *Neuron* 43, 4, 2004, pp. 527-37.

25 Eric E. Zhang, Andrew C. Liu, Tsuyoshi Hirota, Loren J. Miraglia, Genevieve Welch, Pagkapol Y. Pongsawakul, Xianzhong Liu, Ann Atwood, Jon W. Huss, Jeff Janes, Andrew I. Su, John B. Hogenesch, and Steve A. Kay, "A Genome-Wide Rnai Screen for Modifiers of the Circadian Clock in Human Cells", in: *Cell* 139, 1, 2009, pp. 199-210.

26 Paul Smolen, Douglas A. Baxter, and John H. Byrne, "Modeling Circadian Oscillations with Interlocking Positive and Negative Feedback Loops", in: *Journal of Neuroscience* 21, 17, 2001, pp. 6644-56.

27 Angela Relógio, Pal O. Westermark, Thomas Wallach, Katja Schellenberg, Achim Kramer, and Hanspeter Herzl, "Tuning the Mammalian Circadian Clock: Robust Synergy of Two Loops", in: *PLoS Comput Biol* 7, 12, 2011, pp. e1002309.

ing to the concentration of PER:CRY at its mean value, they found that the loop involving BMAL1 was sufficient for oscillations but when they fixed the variables corresponding to CLOCK:BMAL1 and REV-ERB α to their mean values, rendering CLOCK:BMAL1 into a constitutive inhibitor and REV-ERB α into a constitutive activator, the oscillations in the variables representing PER, CRY, and the PER:CRY dimer were shortened and soon damped out. They concluded that the cycle involving REV-ERB α and ROR α was the core mechanism for generating oscillations, and further, since the *Rora* RNA was almost constant even in the first simulation, that the inhibitor *Rev-Erba* was the “driving force” in the oscillator.

One possible response to the divergent results of Smolen et al. and Relógio et al. is to dismiss all such modeling efforts as uninformative (since each explicitly makes simplifying assumptions and so deliberately misrepresents the mechanism). But a different response is to view the models as initial steps towards understanding how the mechanism actually works. A crucial further step is to seek ways to link the models back to the actual mechanism and both examine carefully the assumptions each makes, especially in choosing parameters for the models, and to consider what new experiments might be suggested by the models that can be implemented in actual biological preparations. (Although not directly related to the issue of the two feedback loops, Relógio et al. did make new predictions regarding overexpression of *Rora* and *Rev-Erba* that they then confirmed in slice preparation using a *Bmal1*-luciferase reporter.)

I have highlighted two contributions of systems biology to understanding individual oscillators—identifying additional components and experimenting on models to understand how the operations in the mechanism produced the phenomena. These pursuits support each other. One of the results of identifying additional cell constituents that affect clock operation is to show how clock operation is integrated with many other cell activities, including basic metabolism and cell division. Such discoveries make reliance on modeling ever more crucial to understanding how the mechanism will behave in the interactive context of a cell.

4. SYSTEMS PERSPECTIVES AT HIGHER LEVELS OF ORGANIZATION

At the outset I described how the circadian clock in mammals was initially localized in the SCN. Research on the SCN revealed subpopulations of cells that exhibit different behavior. A basic division was observed between a core region, whose cells express vasoactive intestinal polypeptide (VIP), and a shell region, whose cells express vasopressin.²⁸ Nonetheless, initially it was plausible to assume that the intracellular oscillator functioned similarly in different cells. However, when Welsh cultured SCN neurons on a multi-electrode array that nonetheless retained

28 Anthony N. van den Pol, “The Hypothalamic Suprachiasmatic Nucleus of Rat: Intrinsic Anatomy”, in: *The Journal of Comparative Neurology* 191, 4, 1980, pp. 661-702.

“abundant functional synapses” and recorded from individual neurons, he found that the neurons exhibited a wide variety of phases and periods. Some neurons generated maximal output while others were largely quiescent and their periods ranged from 21.25 to 26.25 hours with a SD of 1.25 hours.²⁹ Since the SCN as a whole produces a regular output and the variation is eliminated even in explants as long as nearly all the connections are maintained, researchers recognized that communication between neurons is responsible for regularizing the behavior of the individual neurons.³⁰

Only computational modeling can illuminate how linking individually variable oscillators into a network could result in each behaving regularly. In a first effort, Gonze, Bernard, Waltermann, Kramer, and Herzog employed Goodwin’s model for an oscillator and added terms for the generation of a diffusible compound such as VIP and for the response to its mean concentration and an equation for determining the mean concentration from that generated by each cell.³¹ They showed that when the parameter affecting the response to the diffusible compound was set to 0 the model behaved as Welsh’s preparation had, but when it was set to 0.5, the oscillators exhibited the synchronization Herzog had found. In their model, Gonze et al. assumed that the network had a fully-connected architecture, one of the modes of organization investigated by graph theorists in the mid-20th century. Two measures are widely employed in analyzing the consequences of network architectures for information flow: characteristic path length and the clustering coefficient. The characteristic path length is the mean of the shortest path between pairs of nodes and reflects how quickly information can be transmitted through the network. The clustering coefficient is the proportion of possible links in local neighborhoods that are actually realized and reflects how much specialized processing can be accomplished by cooperating nodes. Short characteristic path lengths and higher clustering are desirable for information processing and are realized in fully connected networks. However, maintaining complete connectivity between all neurons in a network is metabolically very expensive and so not found in biological systems.

Graph theorists in the mid-20th century also explored two architectures with reduced connections: randomly connected networks and regular lattices. Each only provides one of the valuable characteristics: randomly connected networks exhibit short characteristic path length but low clustering, whereas regular lattices

29 David K. Welsh, Diomedes E. Logothetis, Markus Meister, and Steven M. Reppert, “Individual Neurons Dissociated from Rat Suprachiasmatic Nucleus Express Independently Phased Circadian Firing Rhythms”, in: *Neuron* 14, 4, 1995, pp. 697-706.

30 Erik D. Herzog, Sara J. Aton, Rika Numano, Yoshiyuki Sakaki, and Hajime Tei, “Temporal Precision in the Mammalian Circadian System: A Reliable Clock from Less Reliable Neurons”, in: *Journal of Biological Rhythms* 19, 1, 2004, pp. 35-46.

31 Didier Gonze, Samuel Bernard, Christian Waltermann, Achim Kramer, and Hanspeter Herzog, “Spontaneous Synchronization of Coupled Circadian Oscillators”, in: *Biophysical Journal* 89, 1, 2005, pp. 120-29.

yield high clustering but long characteristic path lengths. However, in 1998 Watts and Strogatz directed attention to a different network architecture. In what they termed “small worlds” most connections are between nearby units, as in regular lattices, but there are a few long-distance connections.³² The clustering coefficient of such networks closely approximates that of regular lattices, but the characteristic path length is approximately that of a fully connected network. Watts and Strogatz also showed that many real world networks, including biological networks such as the neural network of the nematode worm *Caenorhabditis elegans*, exhibit small-world properties and argued that they could synchronize oscillators nearly as quickly as totally connected networks. Not enough is known of the structure of the SCN to ascertain whether it structurally exhibits the properties of a small world. But Vasalou, Herzog, and Henson pursued the strategy of modeling the SCN as a small world and comparing the behavior of the model with the behavior of the SCN.³³ They modeled each neuron using the Leloup and Goldbeter model of the mammalian oscillator modified to include VIP synthesis and set parameter values so that only some of the neurons sustained oscillations when VIP synthesis was suppressed. They organized these into a small world network structure and showed that it would generate synchronization as effectively as a totally connected network. They were also able to capture three other phenomena observed in experimental studies: with VIP (1) the percentage of oscillating neurons in the SCN rises from about 30% to nearly all, (2) the period is extended from approximately 22 to approximately 24 hours, and (3) the variability in periods is largely eliminated.

In these models researchers assumed each cell maintained a given oscillatory pattern except as synchronized with others, but Meeker, Harang, Webb, Welsh, Doyle, Bonnet, Herzog, and Petzold recently employed wavelet analysis which reveals that individual neurons vary in their periodicity, sometimes showing periods greater than 40 hours.³⁴ To understand what factors accounted for the varying behavior of the individual neurons, Meeker et al. modeled the SCN using a stochastic version of the Leloup and Goldbeter mammalian model and through a series of simulations determined that parameters affecting Bmal1 transcription repression and degradation best accounted for the pattern they observed.

The assumption of near decomposability in traditional mechanistic research makes it difficult for such research to identify, let alone explain, how network or-

32 Duncan Watts and Steven Strogatz, “Collective Dynamics of Small Worlds”, in: *Nature* 393, 1998, pp. 440-42.

33 Christina Vasalou, Erik D. Herzog, and Michael A. Henson, “Small-World Network Models of Intercellular Coupling Predict Enhanced Synchronization in the Suprachiasmatic Nucleus”, in: *Journal of Biological Rhythms* 24, 3, 2009, pp. 243-54.

34 Kirsten Meeker, Richard Harang, Alexis B. Webb, David K. Welsh, Francis J. Doyle, Guillaume Bonnet, Erik D. Herzog, and Linda R. Petzold, “Wavelet Measurement Suggests Cause of Period Instability in Mammalian Circadian Neurons”, in: *Journal of Biological Rhythms* 26, 4, 2011, pp. 353-62.

ganization alters the behavior of individual parts of the mechanism. When complemented by the tools of computational modeling and dynamical systems analyses, though, as proposed in accounts of dynamic mechanistic explanation,³⁵ researchers can both simulate such behavior and begin to understand how the organization of the mechanism explains it.

5. CONCLUSIONS

In the 1990s circadian rhythm research made enormous progress in identifying the components of the circadian clock and the operations they performed employing the techniques of genetics and molecular biology. Researchers could recompose the clock in a diagram that showed how the components were related, but to show that by performing the operations attributed to them the mechanism would generate sustained 24-hour oscillations required supplementing these traditional mechanistic approaches with computational modeling approaches developed in systems biology. The need for modeling has grown in the past decade as other approaches from systems biology have revealed more components of cells that affect clock function. As I have illustrated, to begin to understand what parts of the mechanism are responsible for sustained oscillations, researchers resorted to developing simplified models and performing manipulations on them. In addition to facing these challenges in understanding the intracellular mechanism, researchers also came to recognize that the oscillators are incorporated in networks and that only as part of the network do they generate sustained circadian oscillations. Again, to understand how coupling into networks alters the behaviors of the components and generates regular behavior requires modeling and systems analysis. The need to turn to systems biological approaches is driven by discoveries about the mechanism responsible for circadian rhythms.

Department of Philosophy and Center for Chronobiology
University of California, San Diego
La Jolla, CA 92093-0119
USA
bill@mechanism.ucsd.edu

35 See Bechtel, *op. cit.* and Bechtel and Abrahamsen, *op. cit.*